





Electrical Safety Considerations in Large-Scale Electric Vehicle Charging Stations

Bo Wang , *Student Member, IEEE*, Payman Dehghanian , *Member, IEEE*,
Shiyuan Wang , *Student Member, IEEE*, and Massimo Mitolo , *Senior Member, IEEE*

Abstract—Several safety regulations, particularly concerning the charging of electric vehicles (EVs) are developed to ensure electric safety and prevent hazardous accidents, in which safety requirements for the EV supply equipment (EVSE) and the EV battery are two main driving factors. At present, quantitative assessment of electrical safety considering the operation conditions of large-scale EV charging stations (EVCSs) has still remained a challenge. Driven by the hierarchy of hazard control mechanisms, this article proposes a holistic approach to evaluate the electrical safety of the large-scale EVCSs when coupled to renewable power generation. Our approach mainly focuses on several topics on the operational safety of EVCS primarily concerning: 1) the facility degradation which could potentially result in a compromised EVSE reliability performance and EVCS protection failure; 2) the cyberattack challenges when the smart charging and the communication between EVCSs and electric utilities are enabled; and 3) the potential mismatch between the renewable output and EVCS demand, which could trigger the system stability challenges during normal operation and inability to supply the critical EV loads during outages. The proposed framework will provide informative guidelines to the EVCS operators for continuous monitoring and effective management of the day-to-day EVCS operation.

Index Terms—Electric vehicle (EV), electrical safety, EV charging station (EVCS), risk management.

I. INTRODUCTION

THE transportation sector consumes a large portion of fossil fuels with massive air pollution and greenhouse gas emissions, which has raised significant environmental concerns. Organizations and governments have set ambitious targets for the integration of electric vehicles (EVs) into the modern power grids to build, plan, and operate a clean and sustainable energy landscape [1]. With the decreasing cost of EVs, the number of EVs has increased dramatically, many EV charging facilities have been constructed, and many large EV charging stations (EVCSs) are being designed and planned to manage the charging

needs of hundreds of EVs that are seamlessly integrated in the modern power grids of the future.

Many standards and regulation policies related to safely operating an EV have been published, where the primary focuses are on the battery pack, the plugs and connectors, and the EV supply equipment (EVSE) [2]. EV battery performance and safety are considered by the vehicle manufacturers to prevent the battery from combustion, explosion, and other potential accidents resulting from the failure and misoperation of the battery itself [3]. The plugs and connectors, and the EVSE with electrical safety protection features have also been addressed in several standards from a safety standpoint. For instance, the Society of Automotive Engineering (SAE) has published its recommended practices for charging the plug-in EVs (PEVs). The SAE J1772 standard covers the general physical, electrical, and performance requirements for the EV charging systems in North America [4]. The SAE J3068 standard allows the EVs to fully utilize three-phase ac power to charge the batteries. A high degree of safety is recommended for the charging operation mode of the PEVs to comply with the standard's requirements [5].

The electrical safety considerations of EVCSs from the perspective of an EVCS operator are also investigated by policy and research communities. Guidelines are introduced requiring the EVCS design to meet the aforementioned standard's requirements, and the EVCSs are also required to be subject to periodic safety assessments [6]. Fire safety when charging EVs is discussed in [7]. The transformer loss-of-life due to the uncoordinated PEV charging in a parking garage has been analyzed in [8]. The integration of photovoltaic (PV) system and the use of smart charging algorithms can avoid the transformer aging and early replacements. An advanced communication system for EVCSs brings about additional opportunities for the EVCS operator, where a communication assisted protection strategy can alleviate the faults and ensure a safe charging of the EVCS [9]. In [10], the cloud has been used as a platform for online monitoring and analysis of the EVCS data and power quality assessments.

EVCSs can also play an important role in power systems when the communication-assisted smart charging algorithms are deployed. Communications between the EVCS and the utility allow the EVCSs to effectively respond to the utility signals during the system transient operating states, acting as distributed energy resources (DERs) and achieved through effective control of EVs' charging and discharging schedules. The communication between the EVSE and the smart meters connected to

Manuscript received June 11, 2019; accepted August 14, 2019. Date of publication August 20, 2019; date of current version October 18, 2019. Paper 2019-ESafC-0307, approved for publication in the IEEE TRANSACTIONS ON INDUSTRY APPLICATIONS by the Electrical Safety Committee of the IEEE Industry Applications Society. (Corresponding author: Bo Wang.)

B. Wang, P. Dehghanian, and S. Wang are with the Department of Electrical and Computer Engineering, The George Washington University, Washington, DC 20052 USA (e-mail: wangbo@gwu.edu; payman@gwu.edu; shiyuan1225@gwu.edu).

M. Mitolo is with Electrical Engineering Department, Irvine Valley College, Irvine, CA 92618 USA (e-mail: mitolo@ieec.org).

Color versions of one or more of the figures in this article are available online at <http://ieeexplore.ieee.org>.

Digital Object Identifier 10.1109/TIA.2019.2936474

EVs also enables the EVCS to manage the charging schedule of PEVs so that the EVs can mainly charge the batteries during the off-peak hours with low electricity prices. It will also increase the grid flexibility by dispatching the EV loads. The contribution of EVCSs to maintain the grid stability and enhance its flexibility will be significant with the increasing penetration of EVs in the coming future.

While the EVCSs with communication systems enable additional benefits to EVCS operators and the grid performance, this cyber-physical system reveals significant challenges to its own operation as well as the grid performance and has to be well investigated to ensure a safe and secure operation of both. Several research efforts have focused on modeling the cyber-physical power systems and evaluating the impacts [11], [12]. The cyber security and cyber reliability of the distribution systems and the demand side are also studied in [13]–[15]. The EVCS design should also consider the security and reliability of its cyber-physical system and its impacts on the system stability performance. These factors are interdependent [16], [17], and the risk may increase if such factors and their correlation are ignored through the EVCS design and procurement practices. Risk assessment for power dispatch, considering the uncertainty in intermittent wind and PV power output, has been studied in [18] and [19] to address and quantify the cost of expected energy not supplied (EENS) in the system. EV load characteristics should also be considered during the EVCS design procedures to address the prescribed safety requirements for the EVCSs during the operation. Since the EV customer behavior and the corresponding load have different power supply reliability requirements, inability to supply some critical EV loads may cause catastrophic consequences in the grid operation.

The EVCS safety depends on how well the risk management and control mechanisms are implemented within the design processes to prevent hazardous conditions and catastrophic consequences [20]. Centered on the hierarchy of risk control measures [21] that are widely used in safety management systems, we propose a systematic approach to evaluate the electrical safety of EVCSs. The main contributions of this article are summarized as follows.

- 1) We introduce an EVCS architecture and address the EVCS safety considerations in its cyber-physical system and its interactions with the power grid.
- 2) We discuss the interdependence of the safety requirements with the EVCSs operation and develop a risk assessment framework to evaluate its electrical safety.

This article is organized as follows. Section II presents the suggested EVCS architecture. Section III presents its electrical safety considerations and introduces the developed risk assessment model for EVCSs. Section IV presents the numerical case studies and simulation results, followed by the concluding remarks in Section V.

II. ARCHITECTURE OF AN EVCS

With the emerging advancements in the EV charging technologies, there are three main methods [22] widely used to charge an EV: 1) conductive charging, where the battery is

connected by a cable and plugged directly into an EVSE; 2) inductive charging, also called wireless charging, where the electricity is transferred through an air gap from one magnetic coil in the charger to a second magnetic coil fitted into the car; and 3) battery exchange, by swapping the EV battery with fresh ones in a battery swapping station (BSS). The conductive charging method is currently preferred by the EV operators due to its lower cost, higher efficiency, and simpler business model. Some testbeds based on the conductive charging mechanism have been built to test the operation of large EVCSs; for instance, the EVCS at the Argonne National Laboratory with seven EVSEs [23] and the EVCS in Caltech with 54 EVSEs [24].

A. EV Charging Standards and Requirements

The charging level describes the power level of a charging outlet using conductive charging mechanisms. Based on the SAE J1772 in 2017 [25], there are two ac and two dc charging levels as follows.

- 1) AC level 1, also known as home charging, supports the voltage level of 120 V with max current level of 16 A.
- 2) AC level 2, supports 208–240 V and the maximum current is 80 A. As the maximum power here is 19.2 kW, it may be utilized at home, workplace, and public charging facilities.
- 3) DC level 1, with the dc output voltage of 50–1000 with the maximum current of 80 A.
- 4) DC level 2, with the same dc output voltage as dc level 1, but a maximum current that can reach 400 A.

While both ac levels require the EV with an on-board charger to receive the single-phase ac power from the EVSE, the dc levels charge the EV battery directly with dc power using off-board charging, where the dc power can be converted from both single- and three-phase ac power supply of the utility. In contrast to SAE J1772, SAE J3068 in 2018 is a recommended practice for conductive charging that utilizes three-phase ac power. Presenting a symmetric three-phase load enhances the grid stability, especially at high power levels. The SAE J3068 standardizes an ac three-phase capable charging coupler and digital control protocols, offering sufficient power and reliability for the commercial vehicle market with heavy-duty vehicles [26].

With bidirectional digital communications between the EV and the EVSE via single-wire base-band signaling for local control, a large three-phase EVCS provides low-cost, less-complex, and highly reliable charging of EVs. It can also supply both ac and dc power based on the customer preferences. Furthermore, large three-phase EVCSs using conductive charging can operate as DERs to support the grid. The IEEE Standard 1547 in 2018 provides requirements relevant to the performance, operation, testing, safety considerations, and maintenance of the interconnection between utility electric power systems (EPSs) and the DERs. The requirements are universally needed for interconnection of different types of DERs [27], where inability to address such requirements may lead to cascading failures in power systems. For instance, tripping of wind farms during a storm resulted in a major blackout in South Australia in 2016, affecting 650 000 customers [28]. Thus, it requires the EVCS operators to

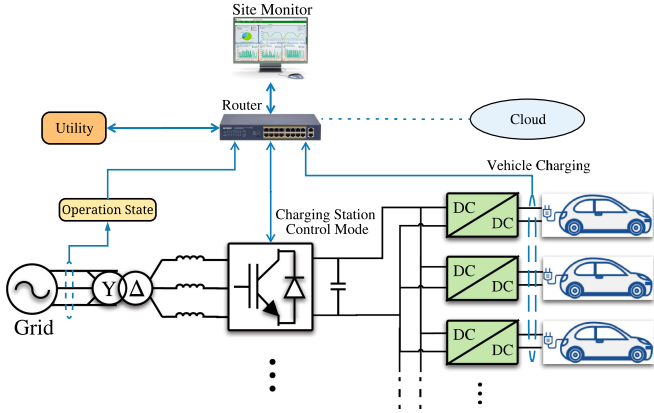

Fig. 1. Overall architecture of an EVCS.

not only account for the traditional considerations of the EVSEs, but also capture the safety of the EVCS cyber-physical system and their interactions with the grid.

B. Proposed EVCS Architecture

We aim at large-scale EVCSs, corresponding to the long-term-parking locations, such as parking garages and parking lots. These EVCSs typically offer 5–25 kW charging capacity through EVSEs (some of them may also offer charging power of 26–60 kW). Only a few EVSEs with the charging capacity of more than 60 kW will be installed by the EVCS operators as the EVSEs with very high charging capacity come at higher installation costs [29], higher degradation of the battery life cycle, and higher charging cost as they may get charged during peak hours with premium electricity price. An EVCS with several EVSEs typically consist of three parts: 1) the physical system that provides the EV charging services; 2) the communication system; and 3) the control center. In compliance with the recent recommended practices and standards, an architecture for a large EVCS is proposed to manage charging of tens to hundreds of EVs that also act as DERs in the grid. The proposed architecture considering the EVCS cyber-physical system is shown in Fig. 1.

The EVCS’s physical system is demonstrated in black and is connected to the distribution grid through a step down transformer. An LC filter is used to filter out harmonics and a voltage source converter (VSC) is used as the ac/dc converter to maintain the dc-link voltage of the capacitor and control the reactive power. The VSC can operate in four-quadrant, and the reactive power injection/absorption is accomplished with the dc-link capacitor. Bidirectional dc/dc converter is used to control the active power. While most current EVSEs have independent ac/dc converters and connect separately to the ac busbar, the EVSEs can share the same ac/dc converter and have multiple parallel dc/dc converters on the dc busbar when EVs are charged with dc power.

The communication system is illustrated in blue. The cyber system transmits the signals between the physical system and the control center. Direct load control can be achieved by enabling and disabling the EV charging, or through proportional

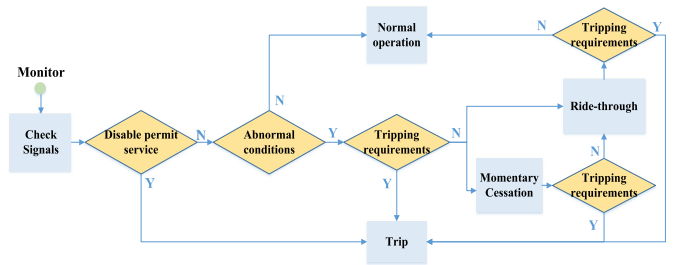

Fig. 2. EVCS operation states and priority diagram as a DER.

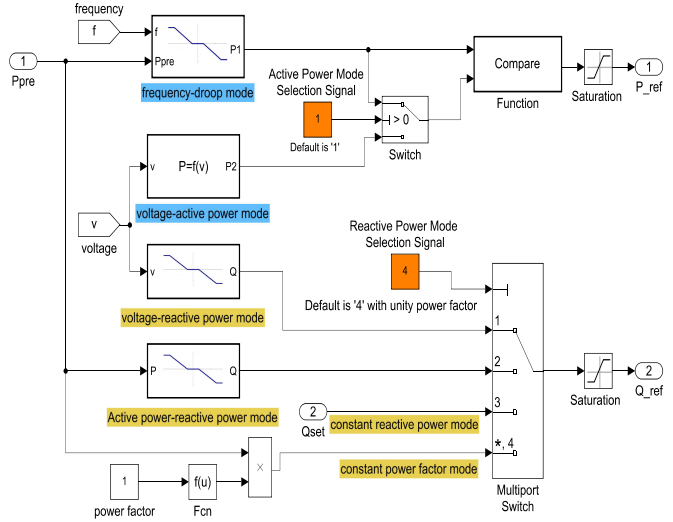

Fig. 3. Recommended ride-through priority and mode selection diagram.

adjustments in the duty cycle of the dc/dc converter. The control center can coordinate the load control of EVs to enable smart charging, and the EVCS can participate into the utility demand side management programs as a DER. The control center will also communicate other signals with the utility. Many EVCS operators analyze the data and run the EV scheduling algorithms on the cloud [23], [24], and thus, the communication between the EVCS and the cloud is also enabled.

The control center with a site monitor and the operation and control platform can monitor and control the EVCS directly or implement the signals sent from the utility and the cloud. Based on the IEEE Std 1547–2018, a DER shall change the operation state based on the DER response priorities. Different operation states of the DER are illustrated in Fig. 2. The EVCS operator checks the communication signals and grid conditions to decide on the operating states. For instance, the EVCS should trip in no more than 2 s when it receives the signals from the utility to disable *permit service*. The control center can also adjust the active/reactive power management modes based on the operation requirements. According to the standard, there are two active power management modes and four reactive power management modes for DERs. The DER can select different control modes during normal operation conditions and ride through, based on the ride-through priority. A recommended ride-through priority and mode selection diagram is shown in Fig. 3. The

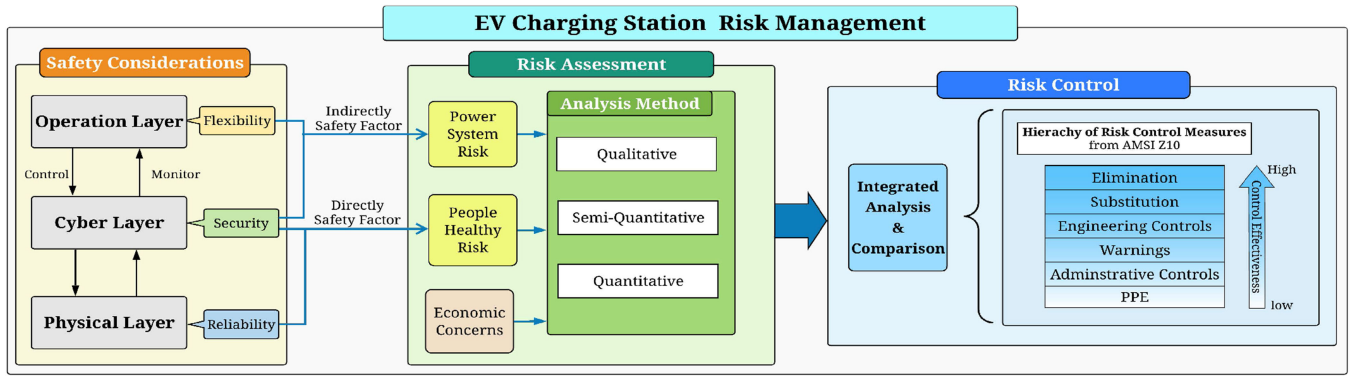

Fig. 4. Risk management framework for the EVCSs.

voltage-active power mode is disabled in default. Once the mode is ON, e.g., if the *Active Power Mode Selection Signal* “-1” is sent from Area EPS to the DER operator, a *Switch* will select the second data signal and the *Compare* function will then select the lesser of the power value between the frequency-droop mode and voltage-active power mode. Reactive power control functions include constant power factor mode, voltage-reactive power mode, active power-reactive power mode, and constant reactive power mode. The DER needs to be capable of activating each mode one at a time. Multiport switch is used to achieve this selection, e.g., if *Reactive Power Mode Selection Signal* “1” is sent from Area EPS to the DER operator, port 1 is selected, and then, the voltage-reactive power mode is activated. Constant power factor mode with unity power factor setting is the default mode of the installed DER, thus, Signal “4” is selected in the default mode.

III. PROPOSED RISK MANAGEMENT MODEL FOR EVCSs

The proposed risk management framework of the EVCS is shown in Fig. 4 and includes three layers: 1) safety considerations of EVCS; 2) risk assessment; and 3) risk control. The safety considerations in different layers of EVCS are explored, risk assessment analytics are suggested, and finally, the integrated analysis and comparisons are done in the design and planning procedures to meet the requirements of the hierarchy of risk control measures.

A. Safety Considerations and Mitigation Methods

The electrical safety offered by the EVSE can be defined, as the probability that it will continue to properly carry out its duties without causing a dangerous voltage to appear on a touchable surface due to random faults. Some faults may compromise safety, but not the functionality of the charger, which may keep working. This very hazardous situation is even more crucial in large-scale EVCSs, which are publicly exposed. Because electrical safety of the EVCS decays in time, it should be assessed to prevent hazardous situations, such as people injury, device damage, unstable operation of the grid, and discontinuity of power supply to EV load. Safety considerations in Fig. 4 include all three layers of the EVCS. The reliability of the EVCS

components, cyber security of communications, and flexibility of EVCS operation should be considered to reduce the risk and mitigate the impacts of the potential hazards.

Conductive charging requires the customers to plug in their EVs to the EVSEs, and thus, the EVSE design should protect the customer against electric shock when the EV is being charged. The protection against electric shock is achieved by implementing two layers of protection—the basic protection (i.e., preventing persons from being in contact with energized parts) and fault protection (i.e., protection in the event of failure of the basic insulation), which is generally obtained via disconnection of the supply. The International Electrotechnical Commission (IEC) defines different charging modes and describes the safety communication protocol between EV and EVSE [30]. Charging mode 3 should be used for ac charging, and charging mode 4 should be used for the fast dc charging in large-scale EVCSs. The two charging modes have control and protection functions installed permanently. The reliability of the EVSE components with electrical safety protection features should also be monitored by the control center and assessed by periodic safety inspections. For instance, the potential failure of ground fault circuit interrupter breaker or charging circuit interrupting devices due to environmental factors (e.g., humidity and aging), or vandalism activities such as copper theft, can create a dangerous situation for EV customers when they are in touch with the EVSE. The cyber reliability is also very important to the EVCS—if the router is down, the EV load management signals could not be implemented, and the communication between the utility and the EVCS also fails. Hence, a very large EVCS should have backup router and battery resources to support the EVCS communication system at minimum cost.

A well designed protection system in EVCS to have a swift fault clearance is also a main factor to ensure the EV charging safety and protect the EVCS equipment. Over-current protection is a major protection function for EVCSs. Adaptive protection with communication assistance is recommended to coordinate the protection devices and to change the protection algorithms of circuit breakers when necessary [9], [31]. However, performance of the adaptive protection primarily relies on the EVCS cyber layer. In cases of delays in signal communications (or cyber system) and protection device failure, the risk will increase

significantly. Hence, hierarchical protection design, in which the upper layer acts as the backup protection for the lower layer, should still be featured and embedded in the adaptive protection to account for communication failure. The use of communication also makes the EVCS protection vulnerable to cyberattacks. The attacker may disable the protective devices, which may potentially compromise the electric safety. Corrective protection should be used to safeguard the EVCS if the adaptive protection devices fail to trip. For example, power devices, such as IGBTs, can switch OFF when they reach their current limits. In addition, with the EVCS cyber-physical system, the circuit breaker conditions can be uploaded to the EVCS control center, which can guide necessary maintenance and life-cycle management using condition monitoring data [32]. Algorithms to detect the device malfunction and cyberattacks can also be developed to enable the EVCS control center to monitor its performance at all times. Suitable fire detection and warning systems should be installed to detect fire scenarios during the charging, which may also be contributed by other factors (e.g., high temperature in summer).

The cyberattack to the internal communication system of EVCSs or the advanced metering infrastructure (AMI) that enables the communication between utility and EVCSs could also affect the grid stability. For example, the attacker can send the disabling permit service signal to trip the EVCS from the grid. This may cause cascading failures when the grid operates in a marginal operating condition. The attacks targeting the EVCS internal communication system and AMI may have limited impact, and the likelihood of manipulating the communication between the utility and the EVCS may be low when the utility connects the DERs using isolated optical fiber systems. However, the EV load management and control employing cloud services expose the EVCS and the grid with additional vulnerabilities to cyber threats and outside intruders. Particularly, the great exposure and interactions of the EVCS energy management systems and the public Internet will change the communication system in power grids from isolated systems to the attack and defend mode, giving birth to a myriad of cyber threats. For example, the distributed denial-of-service (DDoS) attack can coordinate the DoS attacks to cause serious delays or failures in the data transmission between EVCSs and clouds. As a result, the EVCSs may not respond to the frequency disturbances and fail to coordinate with the main grid services during the ride-through operation. The attacker can also send signals to EVCSs to continuously switch ON/OFF the EV load and thereby, can cause grid oscillations. With massive integration of EVCSs in the coming future, the consequences arising from any of the above-mentioned disruptions may be far higher than before, potentially leading to cascading failures and major blackouts in bulk power grids. Hence, the large EVCSs should run the EV load management and control algorithm on their own computer or the utility server, while other data can be uploaded to the public cloud so that the cloud can only read/store the EVCS data.

EVCSs are allowed to over subscribe the EV charging if the total load at any time is within the supply system safety limits. Smart charging considering the EVCS and grid constraints can be implemented to achieve this and avoid the possible

overload and temperature rise of the transformer connected to the EVCS (which will otherwise result in an accelerated transformer loss-of-life). The smart charging assisted by EVCS communication system can also facilitate the EV load recovery after interruptions. The interrupted EV load during the outages can be charged back to the required state of charge (SOC) as long as the EVSE is able to supply the remaining EV load demand before the EV departure time. Although the cold start status—that asks the EVs to start charging within a random time up to 15 min following the interruption—will not allow a simultaneous charging of the EVs and causes the transient stability problem in the grid, the uncoordinated charging still allows all EVs to charge after a short time period and may violate the grid operation constraints. On the contrary, smart charging with communication can estimate the EV load and schedule the charging considering both the transient stability of the grid and steady-state grid operation constraints. Hence, the EVCS communication should be supplied by the backup batteries during the interruption or in the recovery process before EVs start to charge. Large EVCSs with major charging power between 26–60 kW or more than 60 kW are most suitable for areas where drivers park for less than half an hour, such as restaurants. These EV loads are usually regarded as critical loads and may charge during the premium electricity price period. Distributed generators and storage units can be used to mitigate the increased peak loads in such EVCSs and supply the load during the interruption. It is worth mentioning that continuous supply of some critical EV loads (such as hospital EV fleet) is very important as failure in doing so may cause catastrophic consequences. One approach is to build or increase the capacity of the uninterrupted power supply system considering the EV loads. Other alternatives can be to use the plug-in hybrid EV (PHEV) fleet or build the BSSs which reserve the fully charged batteries for the fleet and locate the BSS within short distances.

The safety distance to prevent the EVCS workers from arc flash hazards should also be considered by the EVCS operators. The arc flash boundary for the EVCSs with ac busbar can be calculated by the IEEE Std 1584-2018 [33]. Additional research needs to be done to address the arc flash boundary for the EVCSs with dc busbar. RF hazards [34] need to be considered for large EVCSs with the inductive charging that may be built in the future. To the large BSSs using robotic arms to swap the EV batteries and automated factory to manage and charge the batteries, several issues mentioned earlier (e.g., EVCS cyber-physical system) should still be complied to ensure an electrically safe BSS operation.

B. Risk Assessment Metric

A hazard is defined as the potential for harm and includes all aspects of technology and activity that produce risk. A risk is the likelihood that a hazard will cause harm. In response to the identified hazardous situations for the proposed EVCS architecture and the corresponding safety considerations, we here provide a systematic tool to analyze the risk of EVCSs and take a promising risk control action.

1) *Risk of Injury or Health Damages*: The risk score R_i related to an identified hazard is a function of the likelihood of occurrence of the injury or health damage Po_i and the subsequent impacts and severity Se_i of the event i , calculated using (1). The total risk score Rt which is assessed in (2), is the sum of the risk scores R_i over all potential risk scenarios.

$$R_i = Po_i \times Se_i \quad (1)$$

$$Rt = \sum_i R_i \quad (2)$$

Rt includes the risk of exposing customers to dangerous voltages during the EV charging, workers to potential arc flash during the maintenance, etc. It varies with time and is affected by the effectiveness of site inspection and maintenance. While Rt can be used to estimate the total risk of an EVCS, a heat map of the R_i can be generated with Po and Se as the two axes in order to prioritize the safety issues and take additional controls for events with higher R_i . Although the risk score approach is a semiquantitative method and could not quantify an accurate risk measure, it is a widely used risk assessment method to estimate the risk and can help an effective decision-making and risk control to hazards, including, but not limited to, shocks and electrocution, burns, etc. [35], [36]. The estimated total risk score Rt reflects the current state of risk for the EVCS and can be calibrated by real-world operation data.

2) *Risk to Power System Operation*: Another risk index is the energy not supplied factor ENSF. First, the EENS is calculated using (3) and reflects the grid reliability status and its ability to continuously serve the demands. EENS and EENS' are the sum of the energy not supplied with and without EVCS during each outage event j . The contribution of the EVCS to the changes in the EENS of the system is then assessed via equation (4)

$$EENS = \sum_j EENS_j \quad (3)$$

$$ENSF = \alpha(EENS - EENS') \quad (4)$$

where α indicates the contribution factor of an EVCS to the EENS, and is calculated as the ratio of the EVCS rated capacity to the total capacity of EVCSs that contribute to the interruption. The EV load interruption may not contribute to a large increase of the EENS if the mobility and flexibility of the EV load is taken into account and utilized during feeder-level interruption recovery. Some utility-level interruptions can also be mitigated when the EVs are charged and ready to supply the grid several hours earlier than potential disruptions. Hence, EVCS can contribute to a decrease in EENS. However, EVCSs' failure to ride through and respond to the grid disturbance may lead to a transient stability problem that may finally affect the system reliability and increase the EENS. Hence, ENSF is proposed to reflect the risk of the EVCS cyber and operation layers that contribute to the interruptions.

Approaches on power flow [19] and Monte Carlo simulation analysis are typically used to calculate the system EENS. The state-of-the-art methods could not quantify the impact of communication system and the flexibility in the EVCS smart charging on EENS. The cyber-physical system impact of the

EVCS on the grid and computation of EENS need a cosimulation framework of the cyber-physical power system and integrated evaluation of system stability and reliability. Future work needs to be done to address these research topics. Here, in this article, we introduce the stability risk index Sr to qualitatively reflect the risk imposed by the EVCS cyber layer to the system stability and reliability performance. Qualitative risk assessment is a simple, yet fast and effective, approach commonly used when numerical data are inadequate or unavailable [37]. The risk levels of Sr are here classified as "very low," "low," "medium," "high," and "very high."

C. Discussions on Risk Control

We have discussed several mitigation methods against several hazards facing the EVCS operation. Most mitigation approaches are for the earlier stages in the hierarchy of risk control and should be considered during the EVCS design procedures which are less impacted by the supervision performance and human error. However, a large EVCS with several electrical safety considerations may require sophisticated design and high investments focused on its cyber-physical system. The EVCS operator may wish to maintain a certain level of electrical safety at minimum cost. For example, the EVSEs with safety features are mandatory for all EVCSs considering that the generality of users has minimum knowledge on the electricity, but other EVCS designs are selected based on the EV load characteristics and load demand. The storage or the uninterrupted power system needs to be considered when the EVCSs supply critical EV load routinely. Cyber security of EVCSs with high power capacity and with a DER role to support the grid need to be rigorously checked.

We define the EVCS cost per unit of power (\$/kW) as an index to indicate the economics of the investment

$$Cu = \frac{\text{Capital cost} + \text{Operational cost}}{\text{Rated capacity}} \quad (5)$$

where Cu reflects the life-cycle cost of the EVCS. As shown in Fig. 4, the EVCS design and operation need to consider all indices and do the trade-off among all of them (Rt , Sr , or Cu) when necessary. For instance, an EVCS with a few EVSEs can maintain the basic communication function and use the cloud to manage the EV charging, as it has little impact on the grid. With the same features, a large EVCS with hundreds of EVSEs will have higher Rt and Sr . However, large EVCS might simultaneously reduce the three indices when adding the cyber security enhanced monitoring and control system. For instance, predictive maintenance can be done based on the advanced monitoring system in order to minimize the risk of load interruption. This in turn may reduce the operation cost due to reduced inspection frequency and economic losses. To simplify the process and show the effectiveness of the proposed risk assessment model, we also use the qualitative method to represent the Cu values.

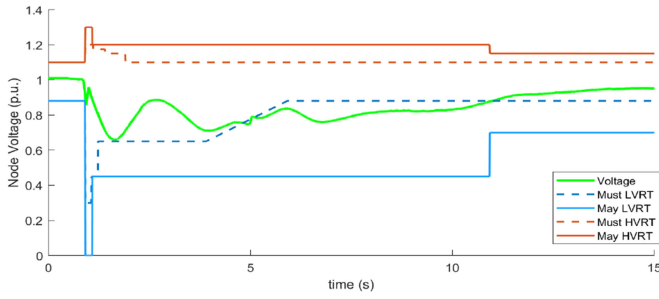

Fig. 6. Low-voltage ride through of the EVCS.

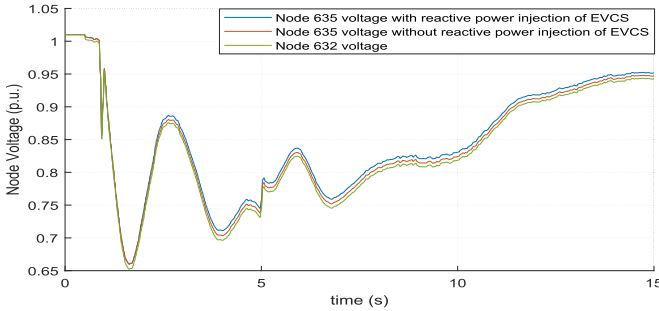

Fig. 7. Comparisons of the EVCSs voltage response during the transients.

Three-phase programmable voltage source is used as the grid supply at node 632 to generate the *voltage event*, where the EVCSs operate under the voltage-reactive power mode. The EVCS voltage curve is shown in Fig. 6. The EVCS can ride through the voltage event and avoid a trip if its design allows for may-ride-through ranges of grid voltage. Hence, the EVCSs should be designed and built to withstand specified abnormal conditions and support the grid stability and reliability while still protecting the equipment from damage and ensuring personnel safety. Fig. 7 shows different voltage responses during the voltage event. Compared with the grid voltage at node 632, the voltage at node 635 without reactive power injection of EVCS but with PV power output, is higher in Case 2. The voltage at node 635 with reactive power injection of EVCS and PV power output in Case 3 and Case 4 is higher than both voltage curves after the required voltage-reactive power response time. This is because the R and X values of distribution overhead lines in the medium-voltage distribution network are similar, where an increase in both nodal active and reactive power will increase the voltage. The reactive power injection to the grid during the low voltage event will bring more benefits when there are induction loads such as air conditioners. However, the EVCSs in Case 3, employing public communication system to select the control mode and monitor the station, is more vulnerable than that in Case 4 due to potential communication delays and failures.

A *frequency event* is also generated by the grid supply at node 632 to test the frequency response of the EVSEs. The grid frequency drops, starting from 60 Hz at 1 s to 59.3 Hz, and then recovers back, as illustrated in Fig. 8(a). The EVCS responds to the frequency event after 0.2 s, when the grid frequency reaches its low-frequency dead-band of 59.8 Hz. It can be seen in

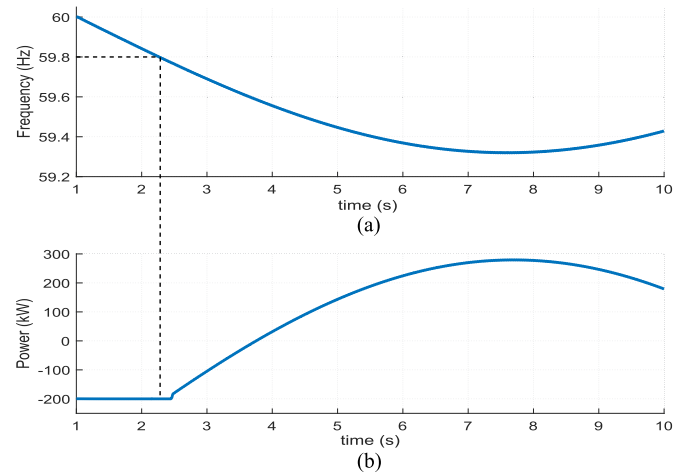

Fig. 8. Frequency response performance. (a) Frequency of the grid, (b) Frequency response of the EVCS.

Fig. 8(b) that instead of charging 0.2 MW before the frequency event, the EVCS reduces the charging power and starts to supply power to the grid when the grid frequency declines. Different from the controllable reactive power output that can provide local voltage support, the active power output of all resources can impact the system frequency and wide-area system stability [39]. EVCS frequency support with the frequency-droop design in Case 3 and 4 will be more beneficial when the number of EVCSs in the system increases, and is highly effective when the system integrates more intermittent renewable sources such as solar and wind. However, the EVCSs frequency support in Case 3 is more vulnerable to the communication delay and malfunctions as the EV power schedule is managed by the public cloud. In case of successful information acquisition and a cyberattack to public network or cloud, the bulk power system safety is threatened and system wide blackout may happen due to inability to preserve the system stability thresholds.

Based on the above analysis, the EVCS in Case 2 has higher stability risk due to the cyber vulnerability. The EVCS in Case 3 has “medium” Sr value as the EVCS can ride through the grid disturbance when no cyber hazard occurs. The EVCS in Case 4 has “low” Sr value as the cyberattack probability is low. The EVCS without communication with the utility and cloud in Case 1 will not be affected by the cyber system performance, but the uncoordinated charging increases the chance that the grid operates near marginal conditions, thereby, the Sr value is “high.” The Sr values for all cases are also included in Table II.

C. Comparisons

As the EVCSs in all four test cases use the same facilities in the physical layer, the EVCS in Case 1 has little investment cost for cyber layer and the Cu is “low”. The Cu values for EVCSs using public communication system in Case 2 and 3 are “medium”. The Cu value for EVCSs using isolated communication system is “high” considering the extra investments in the communication system. However, the EVCS using uncoordinated charging in Case 1 may not do the EVSE oversubscription

and require transformer and distribution line upgrades with a higher operation cost. So the C_u value in Case 1 may increase. The C_u value for the EVCS using the isolated communication system may decrease if the utility has built the AMI with an isolated communication system for grid modernization. As can be seen in Table II, the EVCS configuration in Case 4 has the lowest risk. Although the isolated communication system for EVCSs in Case 4 needs extra investment, it may be preferred by the utilities.

V. CONCLUSION

This article discussed several safety considerations around large EVCS. In order to ensure a safe operation environment of the EVCSs, they need to not only follow the safety requirements for EVSEs [4], but also comply with other existing standards and guidelines, such as the arc flash boundary [33], grid interoperability [27], periodic inspection [6], fire safety [7], and maintenance related to the EVCS facilities discussed in National Fire Protection Association (NFPA) 70B and Canadian Standards Association (CSA) Z463 [40], etc. We have also analyzed the safety considerations of the proposed EVCS cyber-physical system in different layers. Furthermore, a risk assessment model for large EVCSs is proposed, enabling the EVCS operators to evaluate the electrical safety using the hierarchy of hazard control methods. Numerical case studies demonstrated that the risk assessment model for EVCSs can effectively evaluate the safety considerations of large EVCSs and help informative planning and operation decisions.

REFERENCES

- [1] M. Ghavami, S. Essakiappan, and C. Singh, "A framework for reliability evaluation of electric vehicle charging stations," in *Proc. IEEE Power Energy Soc. General Meeting*, Jul. 2016, pp. 1–5.
- [2] J. M. Green, B. Hartman, and P. F. Glowacki, "A system-based view of the standards and certification landscape for electric vehicles," *World Elect. Veh. J.*, vol. 8, no. 2, pp. 564–575, 2016. [Online]. Available: <http://www.mdpi.com/2032-6653/8/2/564>
- [3] K. Zhang, Z. Yin, X. Yang, Z. Yan, and Y. Huang, "Quantitative assessment of electric safety protection for electric vehicle charging equipment," in *Proc. Int. Conf. Circuits, Devices Syst.*, Sep. 2017, pp. 89–94.
- [4] M. C. Falvo, D. Sbordone, I. S. Bayram, and M. Devetsikiotis, "EV charging stations and modes: International standards," in *Proc. Int. Symp. Power Electron., Elect. Drives, Autom. Motion*, Jun. 2014, pp. 1134–1139.
- [5] F. Freschi, M. Mitolo, and R. Tommasini, "Electrical safety of plug-in electric vehicles: Shielding the public from shock," *IEEE Ind. Appl. Mag.*, vol. 24, no. 3, pp. 58–63, May 2018.
- [6] M. Wogan, "Electric vehicle charging safety guidelines," WorkSafe, Wellington, New Zealand, 2016. [Online]. Available: <https://worksafe.govt.nz/laws-and-regulations/regulations/electrical-regulations/regulatory-guidance-notes/electric-vehicle-charging-safety-guidelines/>
- [7] "Risk control—Fire safety when charging electric vehicles," U.K. Fire Protection Assoc., Gloucestershire, U.K., Rep. no. RC59, 2012.
- [8] C. M. Affonso, Q. Yan, and M. Kezunovic, "Risk assessment of transformer loss-of-life due to PEV charging in a parking garage with PV generation," in *Proc. IEEE Power Energy Soc. General Meeting*, Aug. 2018, pp. 1–5.
- [9] G. Naveen, T. H. Yip, and Y. Xie, "Modeling and protection of electric vehicle charging station," in *Proc. 6th IEEE Power India Int. Conf.*, Dec. 2014, pp. 1–6.
- [10] X. Nie *et al.*, "Online monitoring and integrated analysis system for EV charging station," in *Proc. IEEE PES Asia-Pacific Power Energy Eng. Conf.*, Dec. 2013, pp. 1–6.
- [11] S. Xin, Q. Guo, H. Sun, B. Zhang, J. Wang, and C. Chen, "Cyber-physical modeling and cyber-contingency assessment of hierarchical control systems," *IEEE Trans. Smart Grid*, vol. 6, no. 5, pp. 2375–2385, Sep. 2015.
- [12] G. Liang, J. Zhao, F. Luo, S. R. Weller, and Z. Y. Dong, "A review of false data injection attacks against modern power systems," *IEEE Trans. Smart Grid*, vol. 8, no. 4, pp. 1630–1638, Jul. 2017.
- [13] Z. Li, M. Shahidehpour, and F. Aminifar, "Cybersecurity in distributed power systems," in *Proc. IEEE*, vol. 105, no. 7, pp. 1367–1388, Jul. 2017.
- [14] M. H. Kapourchali, M. Sepehry, and V. Aravinthan, "Fault detector and switch placement in cyber-enabled power distribution network," *IEEE Trans. Smart Grid*, vol. 9, no. 2, pp. 980–992, Mar. 2018.
- [15] T. Hong and F. de Len, "Controlling non-synchronous microgrids for load balancing of radial distribution systems," *IEEE Trans. Smart Grid*, vol. 8, no. 6, pp. 2608–2616, Nov. 2017.
- [16] M. Benidris, J. Mitra, and C. Singh, "Integrated evaluation of reliability and stability of power systems," *IEEE Trans. Power Syst.*, vol. 32, no. 5, pp. 4131–4139, Sep. 2017.
- [17] H. Lei, B. Chen, K. L. Butler-Purry, and C. Singh, "Security and reliability perspectives in cyber-physical smart grids," in *Proc. IEEE Innov. Smart Grid Technol. - Asia*, May 2018, pp. 42–47.
- [18] D. Hu and S. M. Ryan, "Stochastic vs. deterministic scheduling of a combined natural gas and power system with uncertain wind energy," *Int. J. Elect. Power Energy Syst.*, vol. 108, pp. 303–313, 2019.
- [19] P. Dehghanian, B. Zhang, T. Dokic, and M. Kezunovic, "Predictive risk analytics for weather-resilient operation of electric power systems," *IEEE Trans. Sustain. Energy*, vol. 10, no. 1, pp. 3–15, Jan. 2019.
- [20] D. R. Crow, D. P. Liggett, and M. A. Scott, "Changing the electrical safety culture," *IEEE Trans. Ind. Appl.*, vol. 54, no. 1, pp. 808–814, Jan. 2018.
- [21] H. L. Floyd, "A practical guide for applying the hierarchy of controls to electrical hazards," *IEEE Trans. Ind. Appl.*, vol. 51, no. 5, pp. 4263–4266, Sep. 2015.
- [22] A. Ahmad, Z. A. Khan, M. S. Alam, and S. Khateeb, "A review of the electric vehicle charging techniques, standards, progression and evolution of EV technologies in Germany," *Smart Sci.*, vol. 6, no. 1, pp. 36–53, 2018.
- [23] T. Bohn and H. Glenn, "A real world technology testbed for electric vehicle smart charging systems and PEV-EVSE interoperability evaluation," in *Proc. IEEE Energy Convers. Congr. Expo.*, Sep. 2016, pp. 1–8.
- [24] Z. J. Lee *et al.*, "Large-scale adaptive electric vehicle charging," in *Proc. IEEE Int. Conf. Commun., Control, Comput. Technol. Smart Grids*, Oct. 2018, pp. 1–7.
- [25] *SAE Electric Vehicle and Plug in Hybrid Electric Vehicle Conductive Charge Coupler*, SAE Int. Standard J1772-2017, Oct. 2017. [Online]. Available: https://www.sae.org/standards/content/j1772_201710/
- [26] *Electric Vehicle Power Transfer System Using a Three-Phase Capable Coupler*, SAE Int. Standard J3068-2018, Apr. 2018. [Online]. Available: https://www.sae.org/standards/content/j3068_201804/
- [27] *IEEE Standard for Interconnection and Interoperability of Distributed Energy Resources With Associated Electric Power Systems Interfaces*, IEEE Standard 1547-2018 (Rev. of IEEE Standard 1547-2003), 2018.
- [28] N. Harmsen, "AEMO releases final report into SA blackout, blames wind farm settings for state-wide power failure," 2017. [Online]. Available: <https://www.abc.net.au/news/2017-03-28/wind-farm-settings-to-blame-for-sa-blackout-aemo-says/8389920>
- [29] "Plug-in electric vehicle handbook for public charging station hosts," U.S. Dept. Energy, Washington, DC, USA, Rep. no. DOE/GO-102012-327, Feb. 07, 2012. [Online]. Available: <https://afdc.energy.gov/files/pdfs/51227.pdf>
- [30] *Electric Vehicle Conductive Charging System - Part 1: General Requirements*, Standard IEC 61851-1:2017, Feb. 2017.
- [31] I. Stoychev and J. Oehm, "Advanced electronic circuit breaker techniques for the use in electric vehicle charging stations," in *Proc. IEEE Int. Conf. Electron., Circuits Syst.*, Dec. 2016, pp. 660–663.
- [32] P. Dehghanian, Y. Guan, and M. Kezunovic, "Real-time life-cycle assessment of high-voltage circuit breakers for maintenance using online condition monitoring data," *IEEE Trans. Ind. Appl.*, vol. 55, no. 2, pp. 1135–1146, Mar. 2019.
- [33] *IEEE Guide for Performing Arc-Flash Hazard Calculations*, IEEE Std 1584-2018 (Rev. of IEEE Std 1584-2002), Nov. 2018.
- [34] L. B. Gordon, L. Cartelli, and N. Graham, "A complete electrical shock hazard classification system and its application," *IEEE Trans. Ind. Appl.*, vol. 54, no. 6, pp. 6554–6565, Nov. 2018.
- [35] "Electrical safety program," Univ. Pennsylvania, Philadelphia, PA, USA, Rev. 11/18/js, 2018. [Online]. Available: <https://ehrs.upenn.edu/health-safety/general-safety/electrical-safety>

- [36] D. T. Roberts, "Applying risk assessment at the worker level: Applications to electrical safety," *IEEE Ind. Appl. Mag.*, vol. 25, no. 1, pp. 18–24, Jan. 2019.
- [37] L.-D. Radu, "Qualitative, semi-quantitative and, quantitative methods for risk assessment: Case of the financial audit," *Analele Stiintifice ale Universitatii "Alexandru Ioan Cuza" din Iasi - Stiinta Economice*, vol. 56, pp. 643–657, 2009. [Online]. Available: <https://econpapers.repec.org/RePEc:aic:journl:y:2009:v:56:p:643-657>
- [38] W. H. Kersting, "Radial distribution test feeders," in *Proc. IEEE Power Eng. Soc. Winter Meeting Conf. (Cat. No.01CH37194)*, Jan. 2001, vol. 2, pp. 908–912.
- [39] "Impact of IEEE 1547 standard on smart inverters," IEEE PES Ind. Tech. Support Task Force, Piscataway, NJ, USA, Rep. no. PES-TR67, 2018.
- [40] T. Branch, "Using CSA Z463 standard to build a foundation for electrical risk management (FFERM)," in *Proc. IEEE Elect. Power Energy Conf.*, Oct. 2018, pp. 1–6.



Bo Wang (S'15) received the B.Sc. degree in automation from Jilin University, Changchun, China, in 2013, and the M.Sc. degree in electrical power and energy from The George Washington University, Washington, DC, USA, in 2015. He is currently working toward the Ph.D. degree at the Department of Electrical and Computer Engineering, The George Washington University.

His research interests include electric vehicles, power system optimization and control, and power system reliability.



Payman Dehghanian (S'11–M'17) received the B.Sc., M.Sc., and Ph.D. degrees, all in electrical engineering, respectively, from the University of Tehran, Tehran, Iran, in 2009, the Sharif University of Technology, Tehran, Iran, in 2011, and Texas A&M University, Texas, TX, USA, in 2017.

He is an Assistant Professor with the Department of Electrical and Computer Engineering, The George Washington University, Washington, DC, USA. His research interests include power system protection and control, power system reliability and resiliency,

asset management, and smart electricity grid applications.

Dr. Dehghanian is the recipient of the 2013 IEEE Iran Section Best M.Sc. Thesis Award in Electrical Engineering, the 2014 and 2015 IEEE Region 5 Outstanding Professional Achievement Awards, and the 2015 IEEE-HKN Outstanding Young Professional Award.



Shiyuan Wang (S'18) received the B.Eng. degree in mechanical engineering from the University of Science and Technology, Beijing, China, in 2012 and the M.Sc. degree in electrical engineering from The George Washington University, Washington, DC, USA, in 2014. He is currently working toward the Ph.D. degree at the Department of Electrical and Computer Engineering, The George Washington University.

His research interests include power system reliability and resiliency, smart grid and renewable energy, power grid harmonic analysis, and application of signal processing in energy analytics.



Massimo Mitolo (SM'03) received the Ph.D. degree in electrical engineering from the University of Napoli Federico II, Italy, in 1990.

He is currently a Full Professor of Electrical Engineering with Irvine Valley College, Irvine, CA, USA, and a Senior Consultant in Electric Power Engineering with Engineering Systems Inc., ESi. He has authored more than 118 journal articles and the books *Electrical Safety of Low-Voltage Systems* (McGraw-Hill, 2009) and *Laboratory Manual for Introduction to Electronics: A Basic Approach* (Pearson, 2013).

His research interests include the analysis and grounding of power systems and electrical safety engineering.

Dr. Mitolo was the recipient of numerous recognitions and best paper awards, including the IEEE-I&CPS Ralph H. Lee Department Prize Paper Award, the IEEE-I&CPS 2015 Department Achievement Award, and the IEEE Region 6 Outstanding Engineer Award. He is currently the Deputy Editor-in-Chief of the IEEE TRANSACTIONS ON INDUSTRY APPLICATIONS. He is active within the Industrial and Commercial Power Systems Department of the IEEE Industry Applications Society (IAS) in numerous committees and working groups. He also serves as an Associate Editor for the IEEE IAS TRANSACTIONS. He is a registered Professional Engineer in the state of California and in Italy.